



D & D D-U-N-S | 87-154-0684

NSIC

ISO 9001 : 2008

www.mechtechcrane.com



TOP PERFORMANCE
SOLUTION FOR
MATERIAL HANDLING EQUIPMENT

mzi **MECH-TECH**
INDUSTRIES

ABOUT US

Mech Tech Industries is in the field of Material Handling Equipment e.g. EOT Cranes, Single Girder Crane, Double Girder Crane, Goods Lift, Jib Crane, Electric Wire Rope Hoist since 2006. We are based at Ahmedabad, India. Our workshop is well-equipped to produce quality product and various range of products. We conduct load /over load test of cranes / hoist in our work.

Mech-Tech is committed to provide the highest quality product and best services after sales .

WHY US....

HIGH QUALITY PRODUCT

COST COMPETITIVENESS

WIDE RANGE OF PRODUCT

BEST SERVICES AFTER SALES

TIMELY DELIVERED

CUSTOMER SATISFACTION

E.O.T CRANES



Mech-Tech Industries is one of manufacturer of “*MECH-TECH*” BRAND EOT Cranes. Electric Overhead Traveling Cranes are designed with factor of safety in accordance to duty classification as per IS-3177. The structured parts of the cranes are designed and manufactured as per IS-807. Cranes are manufactured as per Customer's requirement.

The girders are supported at ends by rigid end carriages that house long travel wheels. The arrangement of end carriage is decided by application as well as number of long travel wheels that support the load.

Manufacturing Capacity up to 30 MT

The cranes find their application mainly for capacities from 0.5 MT up to 30 MT and Span up to 25 Meters. These are commonly used for light, medium and heavy workshop duty applications.

TYPE

■ Single Girder E.O.T. Crane, Capacity up to 10 MT

■ Double Girder E.O.T. Crane, Capacity up to 30 MT

■ Underslung Cranes (Single / Double Girder), Capacity up to 5MT

■ H.O.T. Crane (Single girder / Double Girder), Capacity up to 10MT

■ Flameproof Cranes (Single / Double Girder), Capacity up to 10 MT

■ Crab, End Carriages, panels etc., Capacity up to 30 MT

ELECTRIC WIRE ROPE HOIST

Mech-Tech Industries is one of manufacturer of "MECH-TECH" BRAND Electric Wire Rope Hoist. Electric Wire Rope Hoist are designed accordance with IS-3938

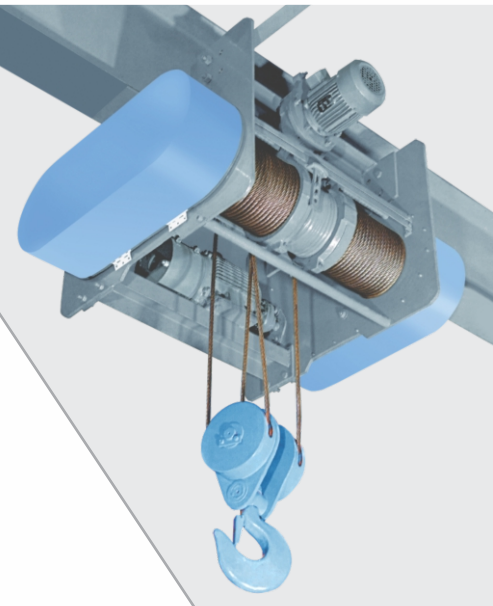
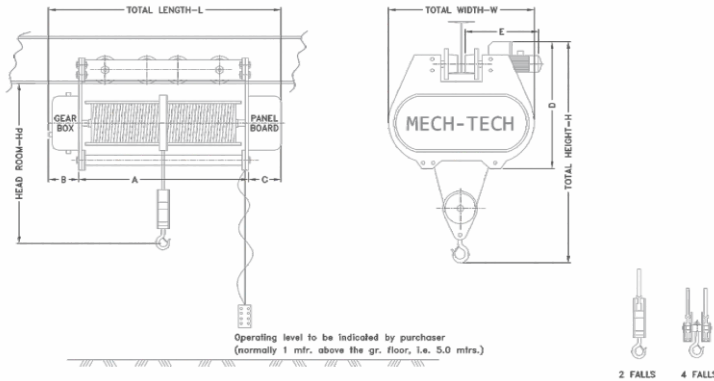

TYPE

- Complete Electric Wire Rope Hoist
- Flameproof Electric Wire Rope Hoist
- Fix suspension type
- Micro speed Electric Wire Rope Hoist
- Curved Type Hoist which run on curved girder

TECHNICAL SPECIFICATION OF "MECH-TECH" BRAND ELECTRIC WIRE ROPE HOIST

Capacity (Kg.)	500	1000	2000	3000	5000	7500	10000	
Standard Lift (mtr)	6	6	6	6	6	6	6	
Hoisting	Speed MPM	4	4	3.5	3.8	3.5	2.8	2.8
	Motor HP	1.5	1.5	3.0	5.0	7.5	10.0	12.5
Cross Travel	Speed MPM	18	18	15	15	15	12	12
	Motor HP	0.25	0.25	0.5	0.5	0.75	1.0	1.0
No. of Fall	2	2	2	2	4	4	4	4
Head Room (Hd)	600	600	650	850	850	850	1250	1350
Total Length (L)	716	716	970	1200	1200	1210	1280	1410
Total Width (W)	555	555	670	740	740	850	980	1000
Total Height (H)	800	800	850	1062	1062	1210	1600	1850
A	436	436	616	680	680	790	810	940
B	120	120	165	182	182	220	220	220
C	160	160	189	200	200	200	250	250
D	500	500	650	720	720	800	900	950
E	310	310	410	410	410	460	530	550
Total Weight (Kg.) Approx	160	160	280	370	400	550	900	1150

MECH-TECH" Brand Electric Wire Rope Hoist range & Specifications

1. **Safe Working Load:** 500 kg. to 10,000 kg.
2. **Heights of Lift:** As per customer specifications
3. **Class of Duty / Standards:** Equivalent to IS 3938
4. **Speeds:** Selected depending on client specifications / applications / shed dimensions
5. **Crane Control:** From floor through Pendant Push Buttons, Optionally through Radio Remote Control
6. **Drive System:** Drive through Squirrel Cage Induction Geared Motors with built-in fail safe brakes
7. **Motors:** Squirrel Cage Induction Hoisting Motors with built-in fail safe brakes for Hoisting. Insulation Class for all motors B/F
8. **Brakes:** Built-in Brakes for Hoisting, Cross Travel Motions
9. **Power Supply System:** To Hoist and Cross Travel through Trailing Cables

GANTRY CRANES

Mech-Tech Industries is one of manufacturer of "MECH-TECH" BRAND Gantry Cranes.

We specialize in manufacturing and supply of high grade gantry cranes such as single girder gantry crane, double girder gantry cranes, high lift gantry crane etc., that are compatible for frequent starting, reversing and braking in accordance with Indian standards.

Manufacturing Capacity up to 30 MT



JIB CRANES

Mech-Tech Industries is one of manufacturer of "MECH-TECH" BRAND Jib Cranes.

Jib Cranes are built to consistently high specification confirming as per IS-807 and IS-3177. JIB cranes are versatile and efficient solutions for moving materials within an individual workstation, for transferring materials from work area to work area or for serving as auxiliary lifting devices under overhead cranes.

Manufacturing Capacity up to 2 MT

Available with 180 degree and 360 degree swiveling boom.
Swiveling through chain at the end of jib arm or electric (if required)



GOODS LIFTS

Mech-Tech Industries is one of manufacturer of "MECH-TECH" BRAND Goods Lifts.

We have a wide range of goods lifts that are known for their ability to manage heavy loads. These lifts are well designed and are manufactured from high grade raw materials that ensures durability. Goods Cage is provided with a collapsible gate & with Goods Cage being guided by supporting guide structure / wall mounted T guide .Mech-Tech hoist is used for hoisting & lowering the Goods Cage from ground floor to top floor. Interlocking system & limit switches are provided for the lifting the material safely.

Manufacturing Capacity up to 10 MT

TYPE OF GOODS LIFTS

- Cage Hoist type
- With Self supporting Structure / Wall mounted without self supporting structure.
- Flame Proof / Non- Flame Proof type

